

# ICE DELIVERY MADE SIMPLE

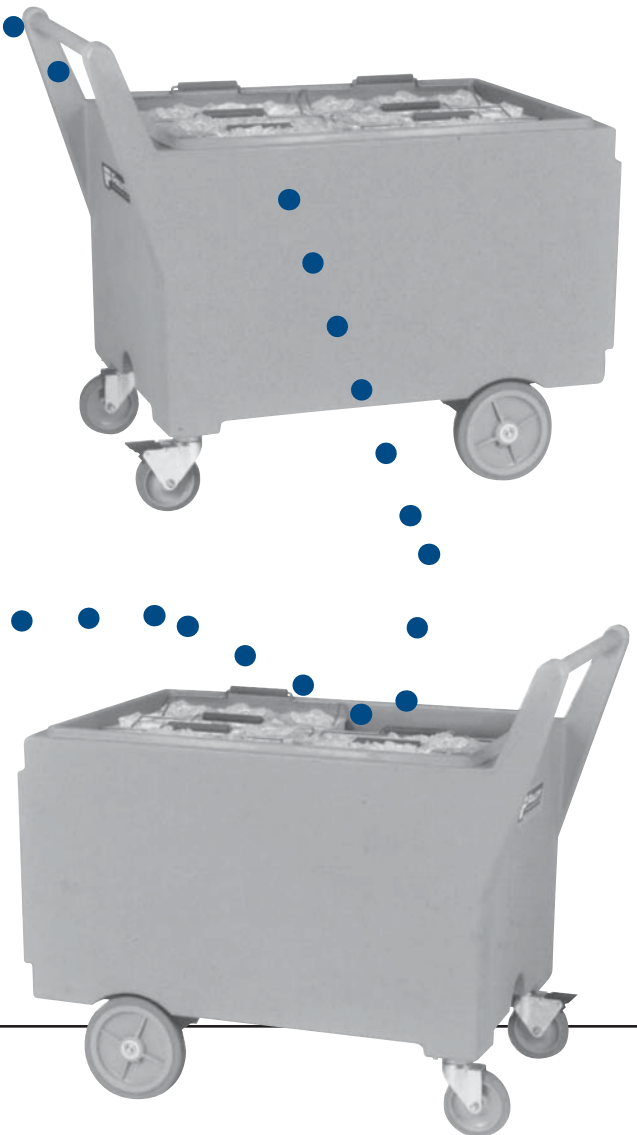

## Follett Ice Storage & Transport Systems

# *The simple way to deliver ice!*

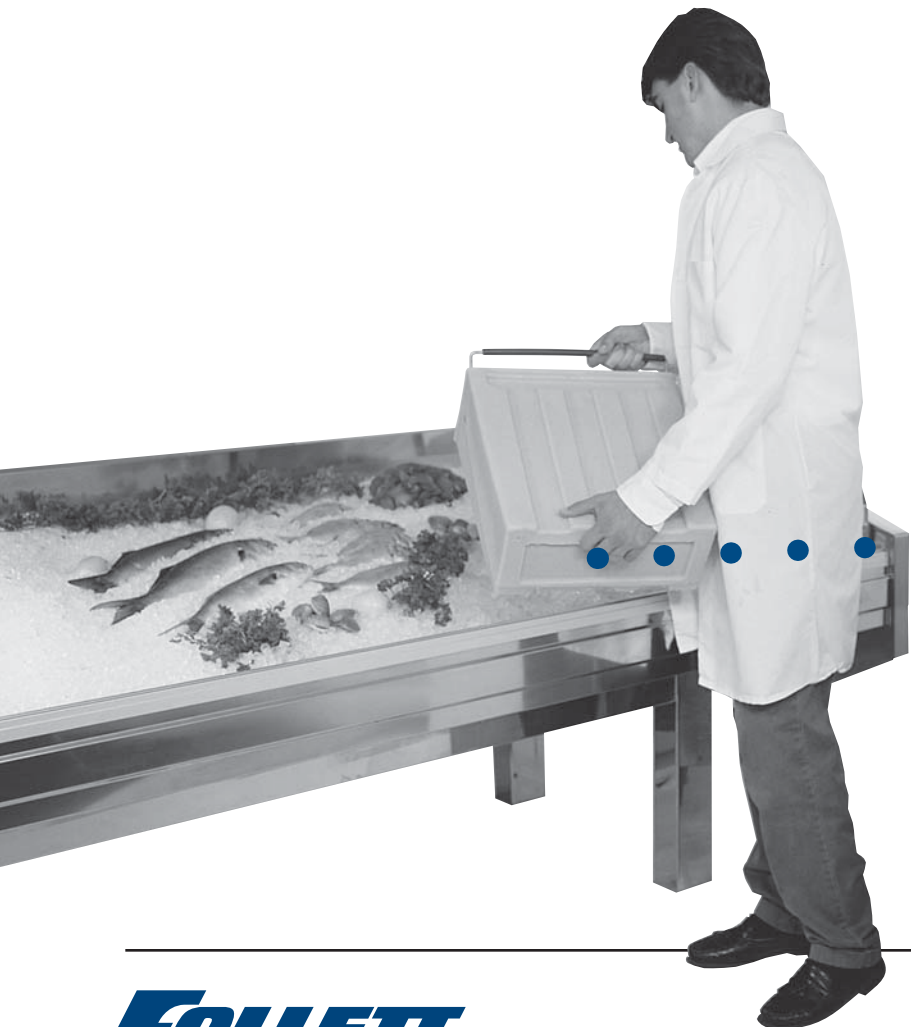

### Labor-saving gravity loading!

- Safer, easier, faster ice removal.
- Ice drops into carts when shutter in elevated bin is opened.
- Eliminates time-consuming, difficult shoveling and scooping.
- Six models store 336 to 1801kg/740 to 3970 lbs of ice.



### Easy, sanitary ice transport!

- Carts move 109kg/240 lbs of ice quickly and easily to usage area; 68kg/1500 lbs when Totes accessory used.
- Extra wide, shallow cart for easy ice removal.
- One-piece polyethylene for durability, easy cleaning.
- Polyethylene lid protects ice during transport.
- Carts drain conveniently to bin drain when parked in bay.

### Totes distribute ice without shoveling or scooping!

- Unique Totes accessory allows easy ice removal from cart and quick filling of displays.
- Eliminates difficult and messy shoveling or scooping of ice from cart.
- Slim Totes design allows efficient ice distribution, even in confined area below breath protectors.



# Quality construction and user-friendly features!

High quality construction and superior design mean long equipment life and exceptional customer satisfaction.

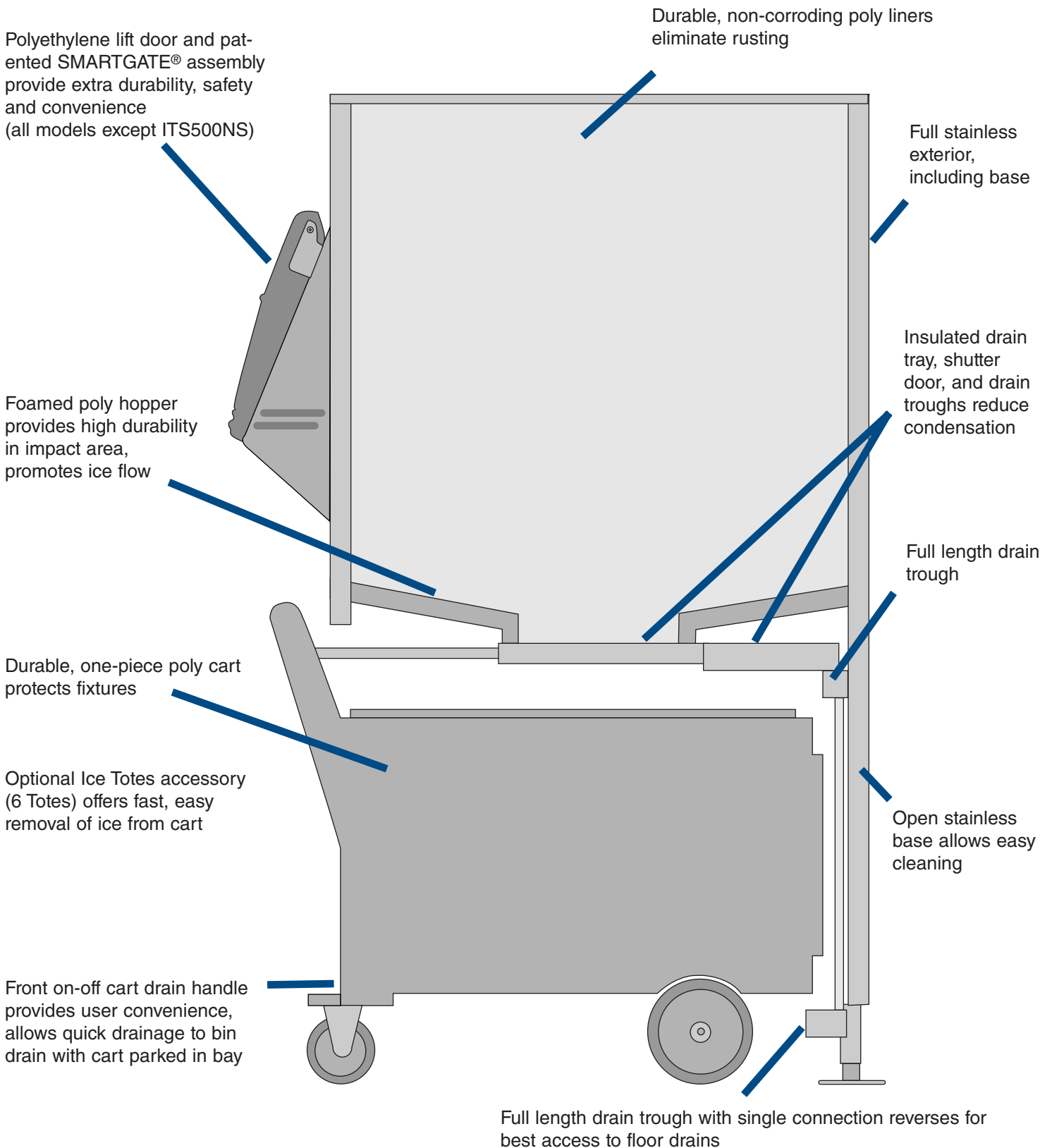

# One, two, or three cart systems with storage capacities to meet virtually every ice storage and transport need

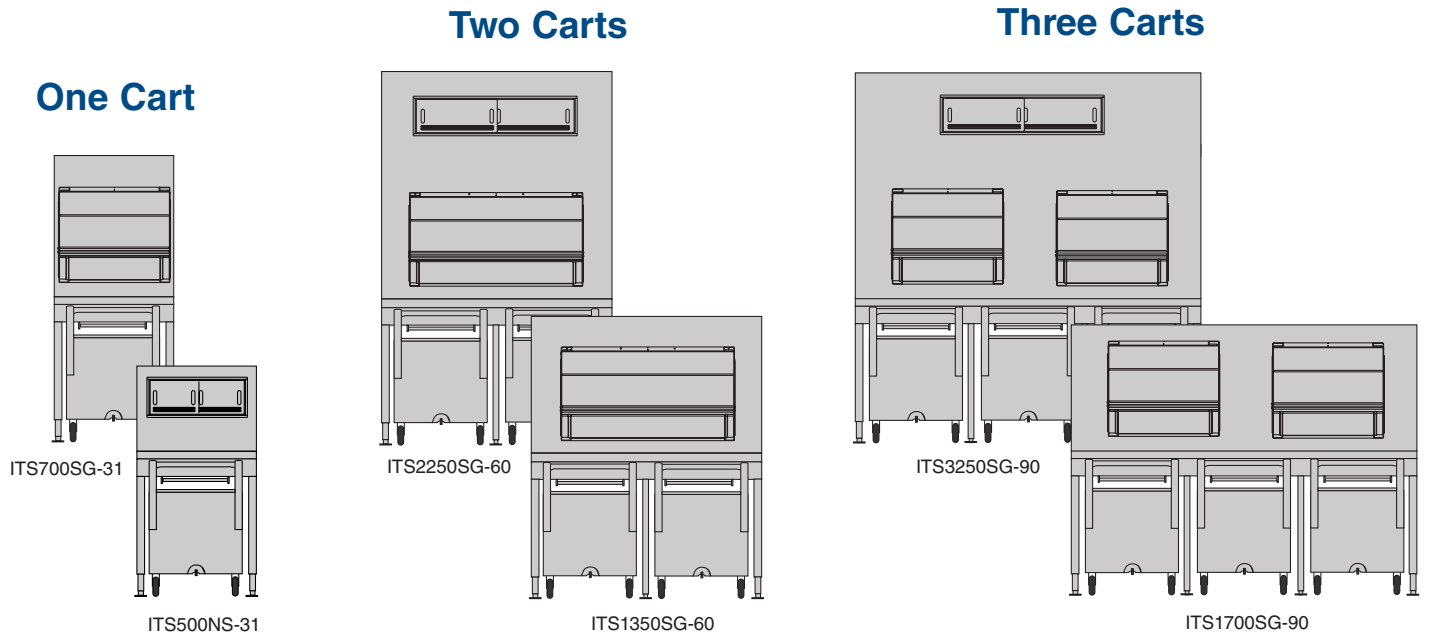

Model Number	Bin Width	Bin Depth	Depth with Door	Height w/ Legs	No. of Carts	Maximum Bin Cap	Max. Cap. w/ Carts
ITS500NS-31	788 mm 31"	1016 mm 40"	1016 mm 40"	1524 mm 60"	1	227 kg 500 lbs	336 kg 740 lbs
ITS700SG-31	788 mm 31"	1016 mm 40"	1220 mm 48"	1905 mm 75"	1 1	318 kg 700 lbs	426 kg 940 lbs
ITS1350SG-60	1524 mm 60"	1016 mm 40"	1220 mm 48"	1905 mm 75"	2 2	612 kg 1350 lbs	830 kg 1830 lbs
ITS2250SG-60	1524 mm 60"	1016 mm 40"	1220 mm 48"	2464 mm 97"	2 2	955 kg 2105 lbs	1173 kg 2585 lbs
ITS1700SG-90	2286 mm 90"	1016 mm 40"	1220 mm 48"	1778 mm 70"	3 3	771 kg 1700 lbs	1098 kg 2420 lbs
ITS3250SG-90	2286 mm 90"	1016 mm 40"	1220 mm 48"	2464 mm 97"	3 3	1474 kg 3250 lbs	1801 kg 3970 lbs

Follett reserves the right to change specifications at any time without obligation. Certifications may vary depending on country of origin.