

ecomaxTM
by **HOBART**

GLASS AND DISHWASHER



made in germany

LOW PRICE
HIGH PERFORMANCE



ECOMAX OR ECOMAX PLUS – IT'S YOUR CHOICE!

ecomax[™]
by **HOBART**

The entry-level models for those who search for a low-cost dishwasher for commercial use. Ideal for start-ups and companies with irregular washing frequency, who invest in a dishwasher for the first time. **ecomax** meets all requirements for hygienic wash results.

ecomax[™] **plus**
by **HOBART**

For budget-oriented operators who seek a plus for comfort and equipment. **ecomax plus** combines all the features of an **ecomax** dishwasher and offers a plus for wash power, energy efficiency, noise reduction and ease of use.



plus

LOW PRICE
HIGH PERFORMANCE



OVERVIEW OF OUR MODELS

made in germany

ecomax[™]
by **HOBART**

Model G404
Compact glasswasher



Model F504
Undercounter dishwasher



Model 602
Hood-type dishwasher



ecomax
by **HOBART** **plus**

Model G403
Compact glasswasher



Model F503
Undercounter dishwasher



plus

ECOMAX G404 **COMPACT GLASSWASHER**

The fast and reliable glasswasher in compact design. Perfect for start-ups, small bars or restaurants.



FEATURES

- Electronic control with digital temperature indication for easy operation
- Rotating wash and rinse arms for an even water distribution
- Indented nozzles prevent blocking
- Integrated counter for cycles and water consumption, e.g. for control of water treatment system
- Deep drawn rack track for easy cleaning
- USB connection for easier service access
- Incl. connection cable, supply and drain hose for immediate operation
- Thermostop function for guaranteed temperatures
- Self-cleaning programme for hygienic cleanliness also in the machine





ECOMAX PLUS G403 COMPACT GLASSWASHER

The compact glasswasher for hotels, bars and restaurants, that are washing more than a hundred glasses a day.

plusFEATURES

+++ additional to ecomax +++

- + Deep-drawn wash tank for easy cleaning
- + Better energy efficiency saves operating costs
- + Double-walled housing and heat insulated front door for reduction of noise and energy losses
- + Tank strainer, coarse filter and pump suction casing secure safe operation
- + Door damping control for long life operation
- + Fully equipped with rinse pressure pump, detergent and rinse aid dispenser and drain pump
- + Optional cabinet base for ergonomic operation





ECOMAX F504 DISHWASHER

With a high capacity of up to 60 racks per hour, this dishwasher is a reliable partner for club houses, bistros, and fast-food restaurants. The practical floor unit fits under every work counter.

FEATURES

- Electronic control with digital temperature indication for easy operation
- Rotating wash and rinse arms for an even water distribution
- Indented nozzles prevent blocking
- Integrated counter for cycles and water consumption, e.g. for control of water treatment system
- Deep drawn rack track for easy cleaning
- USB connection for easier service access
- Incl. connection cable, supply and drain hose for immediate operation
- Thermostop function for guaranteed temperatures
- Self-cleaning programme for hygienic cleanliness also in the machine
- Tank strainer reduces soiling of the tank water
- Rinse pressure pump for optimum flow pressure
- Optional cabinet base for ergonomic operation





ECOMAX PLUS F503 DISHWASHER

Due to the high wash power, the double-walled housing and the robust filter systems, it is the quiet and resource-saving solution for your busy workday life.

plusFEATURES

+++ additional to ecomax +++

- + Deep-drawn wash tank for easy cleaning
- + Better energy efficiency saves operating costs
- + Double-walled housing and heat insulated front door for reduction of noise and energy losses
- + Coarse filter secures safe operation
- + Door damping control for long life operation
- + Fully equipped with rinse pressure pump, detergent and rinse aid dispenser and drain pump



ECOMAX 602 HOOD-TYPE DISHWASHER

The dishwasher for ergonomic and efficient work processes in the kitchen. Combined with tables, it is a powerful partner for the catering and hotel sector.

FEATURES

- The 4-sided closed hood keeps energy and humidity in the system and saves up to 3 kW energy
- Deep-drawn wash tank for easy cleaning
- Rotating wash and rinse arms for an even water distribution
- Intended nozzles prevent blocking
- Incl. connection cable, supply and drain hose for immediate operation
- Thermostop function for guaranteed temperatures
- Self-cleaning programme for hygienic cleanliness also in the machine



DRAWINGS



Glasswasher model **G404**

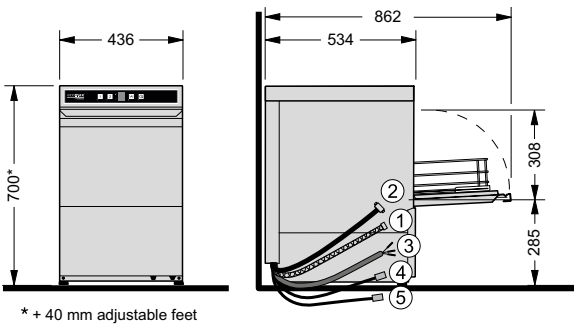

Glasswasher model **G403**

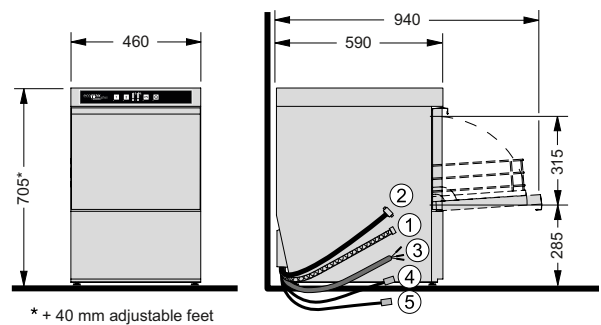

Undercounter dishwasher model **F504**

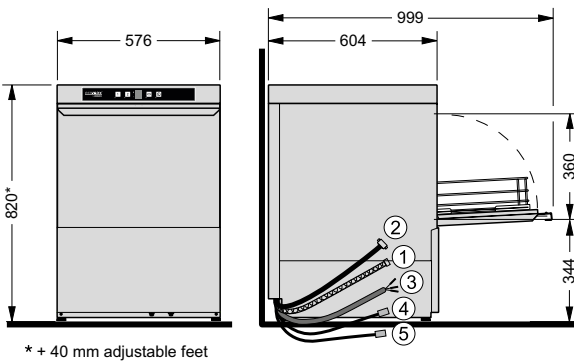

Undercounter dishwasher model **F503**

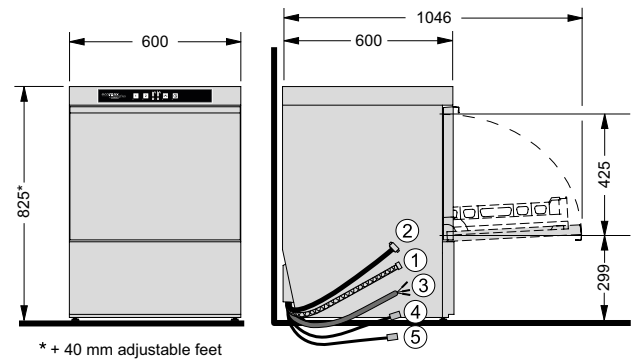

Hood-type dishwasher model **602**

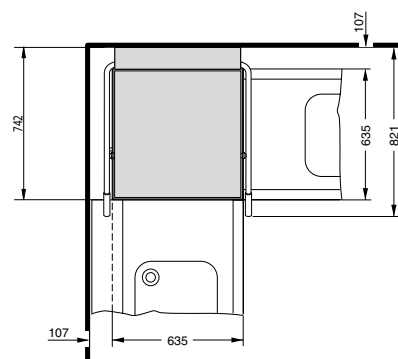
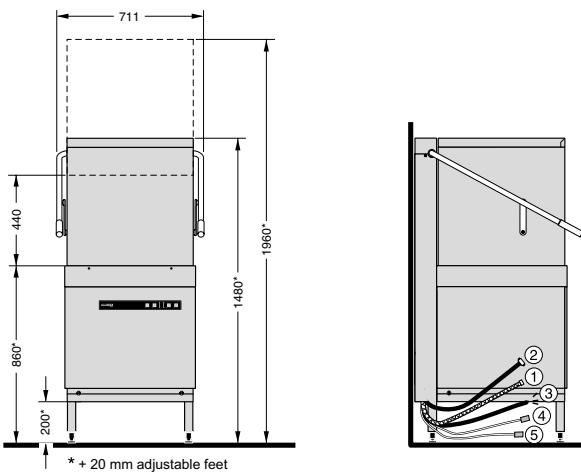

- ① Drain hose
- ② Supply hose
- ③ Connection cable
- ④ Liquid detergent ^{a)}
- ⑤ Rinse aid ^{a)}

^{a)} for machines with external containers

plus

FEATURES

MODELS	GLASSWASHER					UNDERCOUNTER DISHWASHER						HOOD-TYPE DISHWASHER		
	G404 -10	G404 S-10	G404 -12	G404 S-12	plus G403 -11	F504 -10	F504 S-10	F504 -12	F504 S-12	plus F503 -11	F503 S-11	602 -10	602 -12	602 S-12
Integrated water softener*	-	●	-	●	-	-	●	-	●	-	●	-	-	●
External water treatment system**	-	-	-	-	○	○	-	○	-	○	-	-	○	-
Double-walled housing	-	-	-	-	●	-	-	-	-	●	●	-	-	-
Deep-drawn wash tank	-	-	-	-	●	-	-	-	-	●	●	●	●	●
Door damping control	-	-	-	-	●	-	-	-	-	●	●	-	-	-
Tank strainer	-	-	-	-	●	●	●	●	●	●	●	●	●	●
Drain pump	○	○	●	●	●	○	○	●	●	●	●	○	●	●
Rinse pressure pump***	-	●	-	●	●	●	●	●	●	●	●	-	●	●
Rinse aid dispenser	●	●	●	●	●	●	●	●	●	●	●	●	●	●
Detergent dispenser	○	○	●	●	●	○	○	●	●	●	●	○	●	●
HOBART tabling programme	-	-	-	-	-	-	-	-	-	-	-	○	○	○
Base cabinet (435 mm high) with removable door	-	-	-	-	○	○	○	○	○	○	○	-	-	-
Glass rack (4 sloped rows)	●	●	●	●	●	-	-	-	-	-	-	-	-	-
Glass rack (flat)	-	-	-	-	●	-	-	-	-	-	-	-	-	-
Plate rack P-18-12	-	-	-	-	-	●	●	●	●	●	●	●	●	●
Cutlery box CB1	●	●	●	●	-	●	●	●	●	-	-	●	●	●
Cutlery rack with 4 boxes CB4	-	-	-	-	-	-	-	-	-	●	●	-	-	-
Universal flat rack B-00-07	-	-	-	-	-	-	-	-	-	●	●	-	-	-

* For machine protection the water hardness should not exceed 3°dH, if higher we recommend using an integrated water softener or an external water treatment system.

** For use of an external water treatment system, an integrated rinse pressure pump is necessary.

*** Necessary flow pressure without rinse pressure pump: 2 - 6 bar. Flow pressure with integrated rinse pressure pump: 0.8 - 6 bar.

● Inclusive ○ Optional

TECHNICAL SPECIFICATIONS

made in germany

MODELS	ecomax [™] by HOBART			ecomax [™] plus by HOBART	
	G404	F504	602	G403	F503
Cycle times*	60 / 120 sec.	60 / 150 sec.	75 / 150 sec.	90 / 180 sec.	90 / 180 sec.
Rack capacity	60 /h	60 /h	48 /h	40 /h	40 /h
Tank capacity	10 l	25 l	21 l	8 l	10.6 l
Water consumption	2.0 l/rack	2.3 l/rack	2.8 l/rack	2.5 l/rack	2.8 l/rack
Wash pump	0.18 kW	0.34 kW	0.4 kW	0.4 kW	0.5 kW
Tank heating	1.8 kW	1.8 kW	2.5 kW	0.8 kW	0.8 kW
BOOSTER LOADING					
Standard	1.9 kW (230 V)	5.6 kW (400 V)	6.2 kW (400 V)	2.8 kW (230 V)	6.2 kW (400 V)
Alternative	5.6 kW (400 V)	1.9 kW (230 V)	–	4.2 kW (400 V)	2.1 kW (230 V)
TOTAL CONNECTED LOAD					
Standard	2.1 kW (230 V)	5.9 kW (400 V)	6.6 kW (400 V)	3.2 kW (230 V)	7.5 kW (400 V)
Alternative	5.8 kW (400 V)	2.2 kW (230 V)	–	5.4 kW (400 V)	3.4 kW (230 V)
Rated voltage	230 / 50 / 1 (400 / 50 / 3N)	400 / 50 / 3N (230 / 50 / 1)	400 / 50 / 3N –	230 / 50 / 1 (400 / 50 / 3N)	400 / 50 / 3N (230 / 50 / 1)
Width	436 mm	576 mm	635 mm	460 mm	600 mm
Depth	534 mm	604 mm	742 mm	590 mm	600 mm
Height	700 mm	820 mm	1.480 (1.960) mm	705 mm	825 mm
Loading height	308 mm	360 mm	440 mm	315 mm	425 mm
Rack size	390 x 390 mm	500 x 500 mm	500 x 500 mm	400 x 400 mm	500 x 500 mm

* The machine is equipped with an automatic cycle-time control which ensures hygienic rinse temperatures even on a cold-water supply or with reduced heating performance.

HYLINE HYGIENE RANGE DETERGENT / RINSE AID



*Highly-concentrated liquid detergents for use in commercial dishwashers. Extremely effective and therefore economic in use. Tailor-made for **ecomax** and **ecomax plus** dishwashers.*

Highly-concentrated rinse aid for use in commercial dishwashers. Makes glasses and cutlery shining and provides a spotlessly clean wash result.

Glass detergent HLG-10

Protects decor, prevents glass corrosion, excellent beer foam stability, chlorine-free, suitable for use with soft water
11 kg

Universal detergent HLU-31

Excellent grease removal capacity, contains active chlorine, suitable for use with hard water
12 kg

Glass rinse aid HLG-1000

High-concentration formulation for glasses, slightly acidic, protects decor, fast drying, excellent beer foam stability
10 l

Universal detergent HLB-20

Excellent starch and grease removal capacity, high cleaning performance, suitable for use with medium-hard and hard water, chlorine-free
12 kg / 24 kg

Universal detergent HLU-32

Excellent starch removal capacity, chlorine-free, suitable for use with soft water
12 kg

Universal rinse aid HLU-3000

High-concentration formulation for all wash ware, neutral, fast drying outstanding drip-off properties
10 l

Universal detergent HLU-30

Outstanding bleaching effect, contains active chlorine, suitable for use with soft and medium-hard water
12 kg / 24 kg

Aluminium detergent HLA-40

Suitable for aluminium and stainless steel wash ware, excellent grease and protein removal capacity, protects material, chlorine-free
12 kg

Rinse aid for demineralised water HLD-5000

High-concentration-formulation for all wash ware in combination with a reverse osmosis or demineralisation cartridges, protects decor, outstanding drip-off properties, spotless drying results
10 l



HYDROLINE WATER TREATMENT



Always the exactly right water quality for your application – whether your focus is on protecting your machine efficiently against limescale, or on ensuring that your wine glasses are free of stains after washing.

External single-chamber softener SE-H

Protects heating rods against limescale and reduces detergent consumption. Time-controlled automatic regeneration.

External double-chamber softener SD-H

Protects heating rods against limescale and reduces detergent consumption. Regeneration takes place parallel to the cleaning process.

Partial demineralisation cartridge STAR PD

Residue-free removal of hardness components from the water.

Full demineralisation cartridge STAR EXTRA FD

Removes all minerals from the water. For brilliant wash results for glasses and cutlery.

Reverse osmosis RO-S

Removes all minerals and particles from the water. For brilliant wash results for glasses and cutlery.

HYDROLINE	PROTECT SE-H	PROTECT SD-H	STAR PD	STAR EXTRA FD	PURE RO-S
Model	Single-chamber softener	Double-chamber softener	Partial demineralisation	Full demineralisation	Reverse osmosis
Supply water temperature	4 - 65°C	4 - 65°C	4 - 60°C	4 - 60°C	5 - 35°C
Supply capacity (continuously)	10 l/min	20 l/min	5 l/min	5 l/min	2.0 l/min
Flow pressure	3 - 6 bar	3 - 7 bar	2 - 6 bar	2 - 6 bar	1 - 6 bar
Supply hose	R 3/4"	R 3/4"	R 3/4"	R 3/4"	R 3/4"
Drain hose	R 3/4"	R 3/4"	R 3/4"	R 3/4"	R 3/4"
Regeneration type	time-controlled	quantity-controlled	–	–	–
Capacity	1,000 l at 8°dH (total hardness)	1,140 l at 8°dH (total hardness)	13,000 l at 10°dH (carbonate hardness)	5,400 l at 10°dH (total hardness)	–
Voltage	230/50/1*	–	–	–	230/50/1*
Total connected load	0.03 kW	–	–	–	0.2 kW

For machine protection the water hardness should not exceed 3°dH, if higher we recommend using an integrated water softener or an external water treatment system. For a water hardness of 10°dH and up, an external upstream softening system is recommended to protect the RO-S membrane against plugging. For a water hardness of 35°dH and up, an upstream softening system is mandatory for the operation of the RO-S.

* A 230 V connection is needed on site

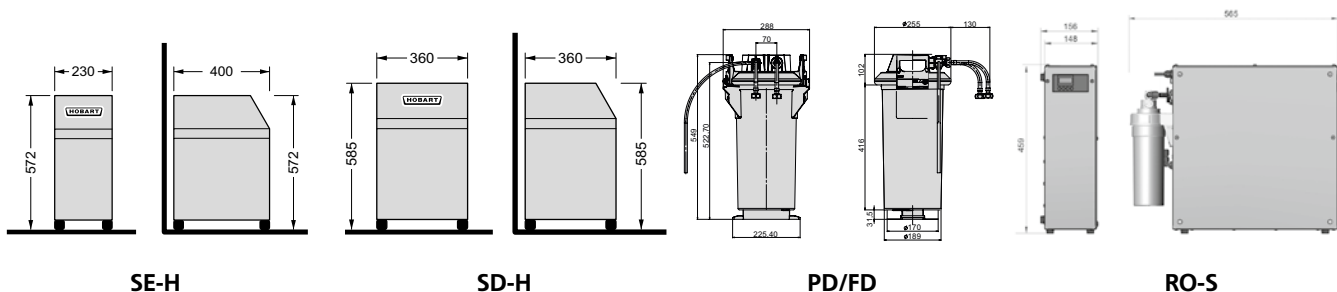



A registered brand of HOBART GmbH
A company of the ITW Group

Robert-Bosch-Straße 17 · 77656 Offenburg · info@ecomaxbyhobart.com
Phone +49 (0) 781 600 2820 · Fax +49 (0) 781 600 2819

www.ecomaxbyHOBART.com



The details given in this brochure are correct as of 06/2018.
We reserve the right to technical or design modifications.