



# HOSHIZAKI

## KM-115B

Crescent EDGE Ice Make (Self Contained)



<b>Production Capacity</b>	Up to 112 kg/24h*
<b>Storage Bin Capacity</b>	Up to 45 kg
<b>Outside Dimensions W x D x H</b>	612 x 712 x 992 mm (Legs add 152mm)
<b>Electrical Supply</b>	220-240V, 50 Hz 220-240V, 60 Hz
<b>Electrical Capacity</b>	50 Hz: 0,598 kW 60 Hz: 0,648 kW
<b>Weight Gross / Net</b>	82/62 kg
<b>Condenser</b>	Air-Cooled
<b>Refrigerant</b>	R404A - CO <sub>2</sub> eq:1020 kg
<b>Type of Ice</b>	Crescent EDGE
<b>Air Filter</b>	Removable air filter

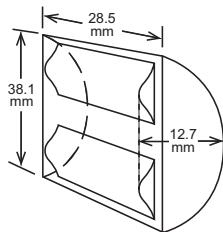

\*Air Temperature 10°C / Water Temperature 10°C. Based on 50 Hz air cooled model.

**Double sided ice making system with stainless steel for better longevity and hygiene**

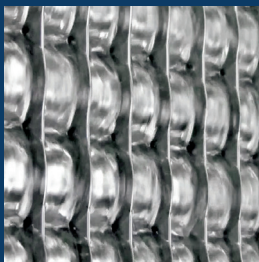

**Versatile usage for drinks, display, bottle cooling and more**



**Audible alert when the machine is in need of service with the EverCheck™ control board**



Subject to technical alterations

**Hoshizaki Europe B.V.**  
**Headquarters Export EMEA**  
Burgemeester Stramanweg 101  
1101 AA Amsterdam  
The Netherlands

sales@hoshizaki.nl  
Tel. +31 (0)20 6918499

Please visit our website for further information:  
[www.hoshizaki-europe.com](http://www.hoshizaki-europe.com)





# HOSHIZAKI

## KM-115B

Technical Drawings

Top View

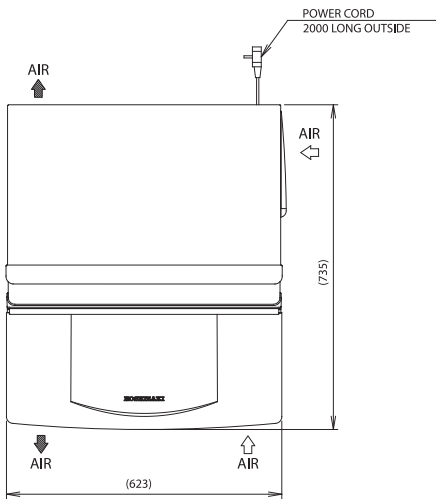

Front View

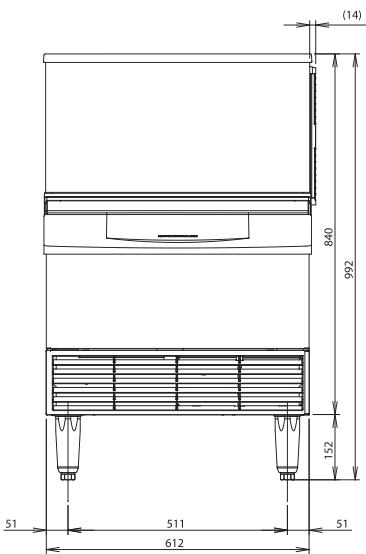

Side View

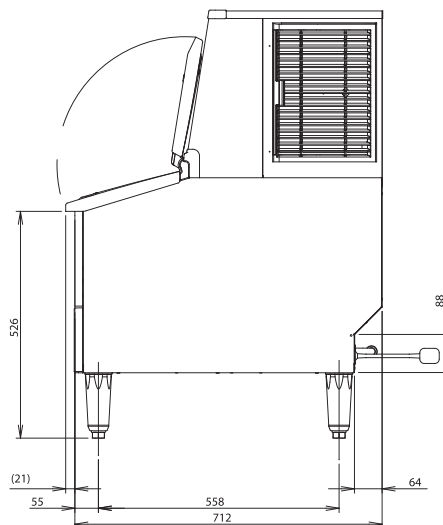

Rear View

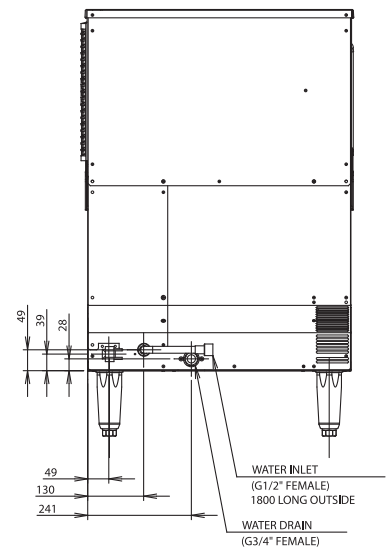

Specifications: mm  
Subject to technical alterations

**Hoshizaki Europe B.V.**  
**Headquarters Export EMEA**  
Burgemeester Stramanweg 101  
1101 AA Amsterdam  
The Netherlands

sales@hoshizaki.nl  
Tel. +31 (0)20 6918499

Please visit our website for further information:  
[www.hoshizaki-europe.com](http://www.hoshizaki-europe.com)

