

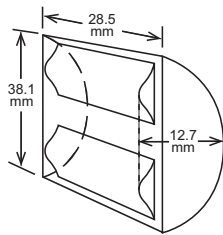

HOSHIZAKI

KM-520MAJ-E

Crescent EDGE Ice Maker (Modular)

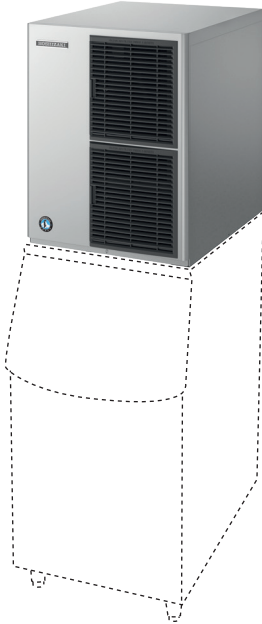

Production Capacity	Up to 238 kg/24h*
Outside Dimensions W x D x H	559 x 695 x 711 mm
Electrical Supply	220-240V, 50 Hz
Electrical Capacity	50 Hz: 1,2 kW
Weight Gross / Net	68/59 kg
Condenser	Air-Cooled
Refrigerant	R404A - CO ₂ eq:1961 kg
Type of Ice	Crescent EDGE
Air Filter	Removable air filter

Corresponding Bins & Top Kits:

Bin	Top Kit
B-301SA	Top Kit not required
B-501SA	TK 8D
B-801SA	TK 8D and TK 18D
B-700SF	TK 22
B-900SF	TK 22 + 8

*Air Temperature 21°C / Water Temperature 10°C.

Double sided ice making system with stainless steel for better longevity and hygiene

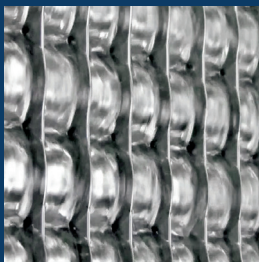

Versatile usage for drinks, display, bottle cooling and more



Audible alert when the machine is in need of service with the EverCheck™ control board



Subject to technical alterations

Hoshizaki Europe B.V.
Headquarters Export EMEA
Burgemeester Stramanweg 101
1101 AA Amsterdam
The Netherlands

sales@hoshizaki.nl
Tel. +31 (0)20 6918499

Please visit our website for further information:
www.hoshizaki-europe.com





HOSHIZAKI

KM-520MAJ-E

Technical Drawings

Front View

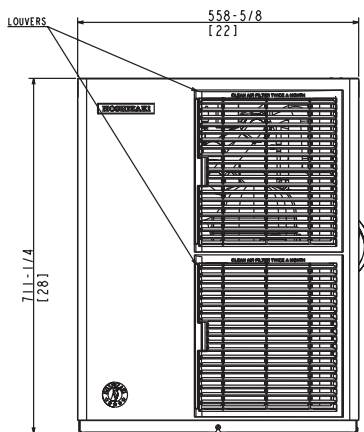

Side View

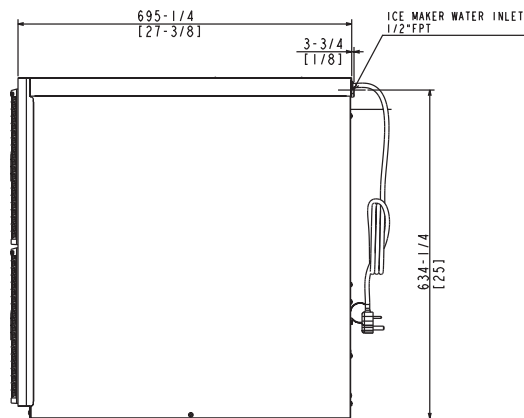

Rear View

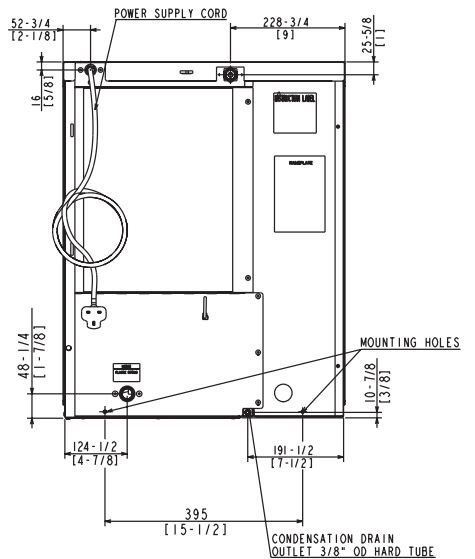

Base View

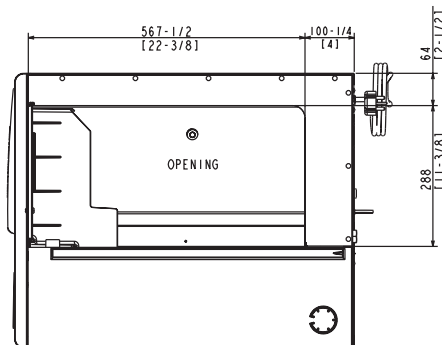

Specifications: mm/inches
Subject to technical alterations

Hoshizaki Europe B.V.
Headquarters Export EMEA
Burgemeester Stramanweg 101
1101 AA Amsterdam
The Netherlands

sales@hoshizaki.nl
Tel. +31 (0)20 6918499

Please visit our website for further information:
www.hoshizaki-europe.com

